

DETAIL L45SP400
6 TPI, 1 THREAD TURN
Ø.500" CUTTER
SCALE 2.000

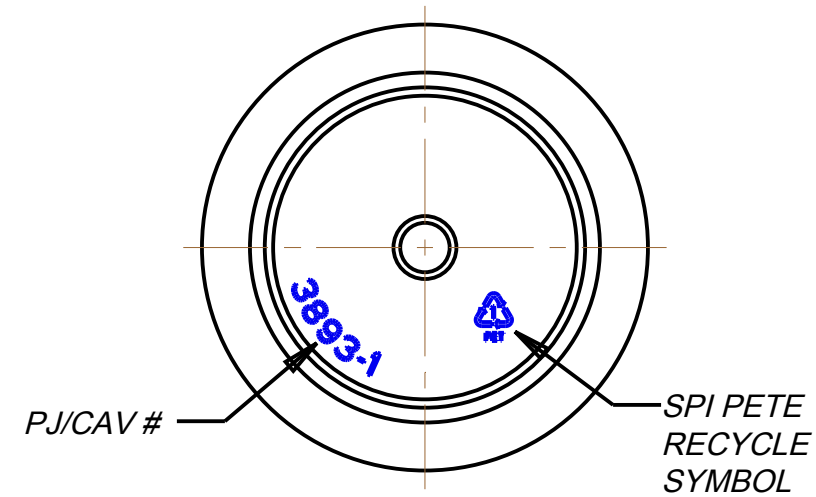

NPD # 3893						
All measurements are in inches, [mm]	Color	Min. Thk (in)	Weight (g)	Overflow (mL)	Revisions	
		TBD	28.0 ± 2	179 ± 6		
Tolerance: Where not shown	NECK FINISH	L45SP400			Scale: 1.000	Drawn By:
Decimal ±0.05 [1.27] Angular ±1°	MATERIAL:	PET			Date: 22-Jul-14	
					150cc 45mm PACKER	DwgRev
					Approved By:	Drawing NO:
						P0150PKSS045A