

TOP VIEW

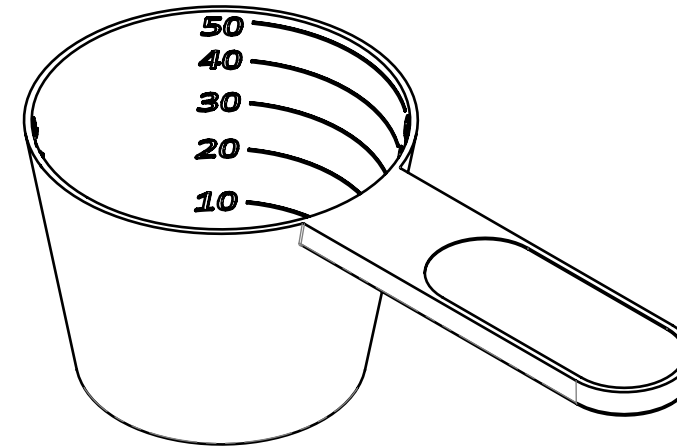

ISO VIEW

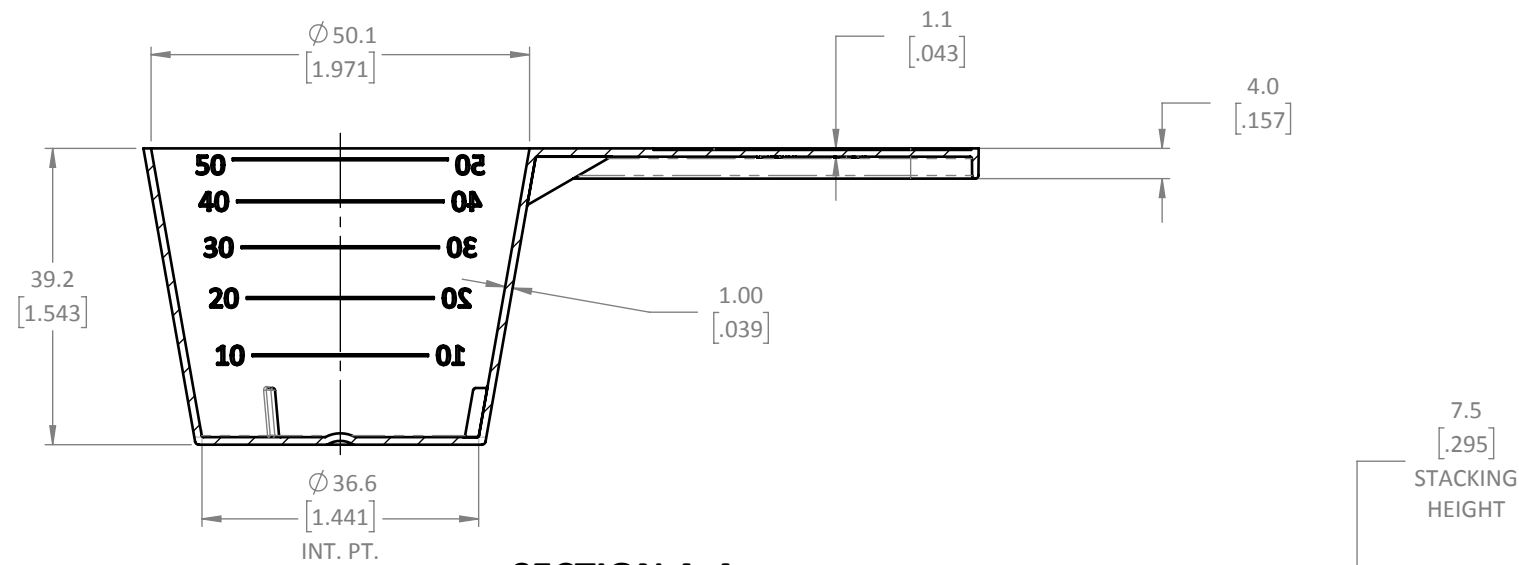

SECTION A-A

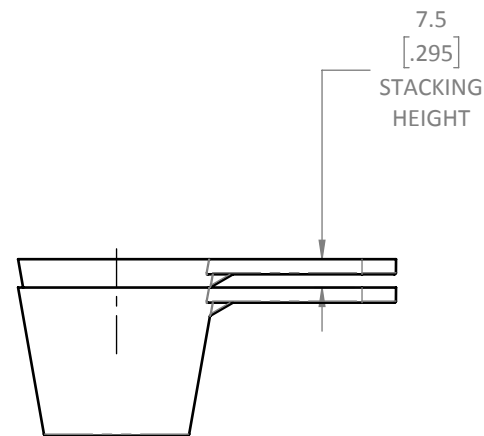

STACKING VIEW
SCALE 1 : 2

LAYER PACK ESTIMATES:

2150 scoop/box

Box weight = 14.8 kgs approx.

Box Size (LxWxH): 585x385x280

PRELIMINARY
DO NOT USE FOR MANUFACTURING

DRAWN	SCALE 1:1	ESTIMATED WEIGHT: 6.8 G (APPROX.)
CHD.	MATERIAL POLYPROPYLENE	
APRD.	DATE 27-MAR-2017	TITLE 50ml Scoop
UNLESS SPECIFIED DIMENSIONS ARE IN MILLIMETERS AND [BRACKETED] ARE IN INCHES		PART# 50ml Scoop_Med Handle
TOLERANCES: 2 DECIMALS ±0.25 3 DECIMALS ±.010 1 DECIMAL ±0.5 2 DECIMALS ±.02 ANGULAR ±2°		REV. 0

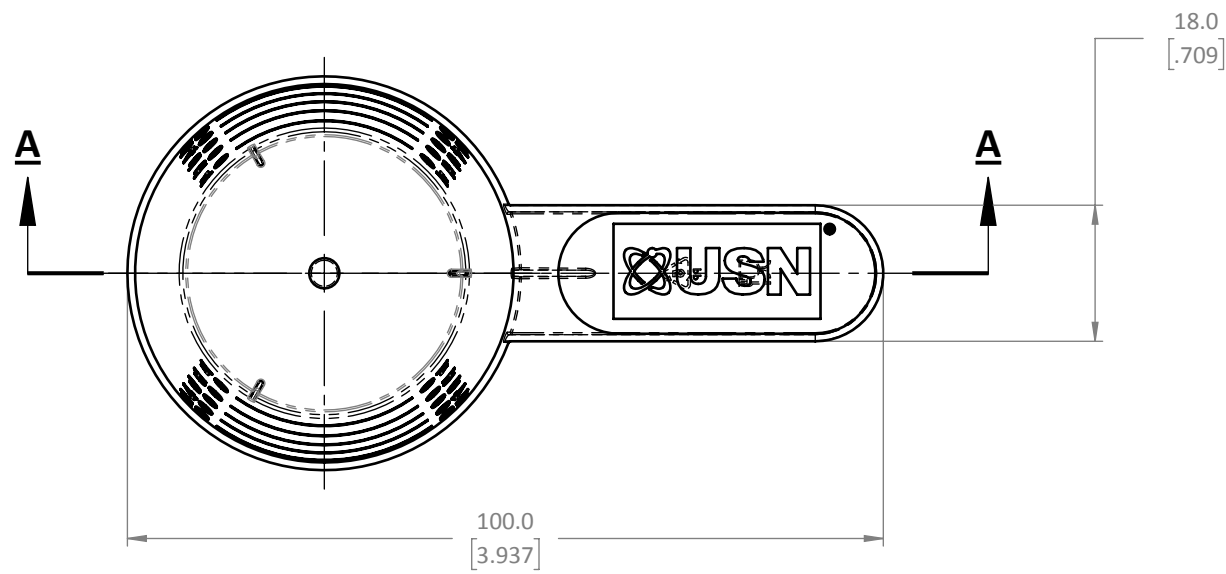

TOP VIEW

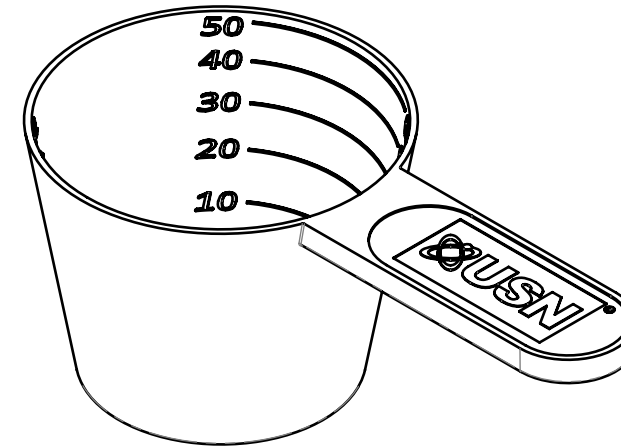

ISO VIEW

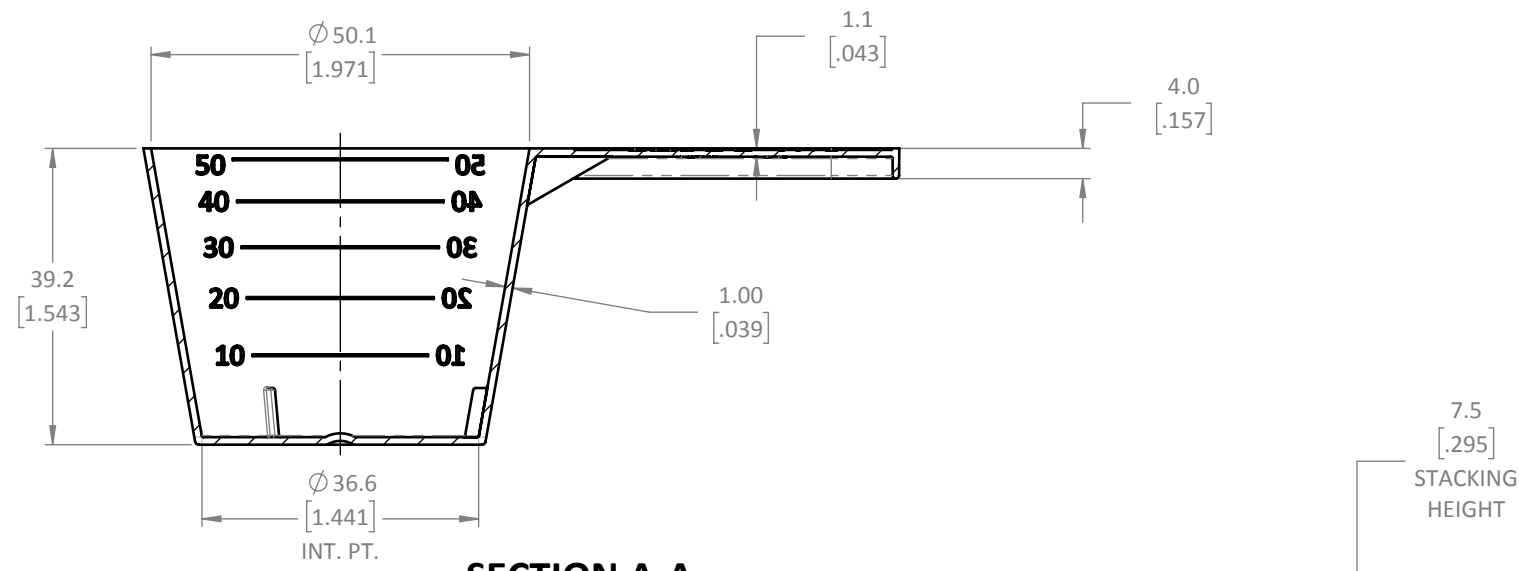

SECTION A-A

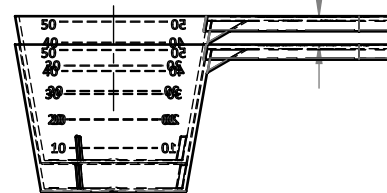

**STACKING VIEW
SCALE 1 : 2**

LAYER PACK ESTIMATES:

2150 scoop/box

Box weight = 14.8 kgs approx.

Box Size (LxWxH): 585x385x280

PRELIMINARY
DO NOT USE FOR MANUFACTURING

DRAWN	SCALE 1:1	ESTIMATED WEIGHT: 6.5 G (APPROX.)		
CHD.	MATERIAL POLYPROPYLENE			
APRD.	DATE 27-MAR-2017	TITLE 50ml SCOOP		
UNLESS SPECIFIED DIMENSIONS ARE IN MILLIMETERS AND [BRACKETED] ARE IN INCHES		PART# 50ml Scoop	REV. 2	
TOLERANCES: 2 DECIMALS ±0.25 3 DECIMALS ±.010 1 DECIMAL ±0.5 2 DECIMALS ±.02 ANGULAR ±2°				